

SERIE F DRF - DGF - GRF - APF - MAF - SMF

INFORMACIÓN - FAMILIA - SERIE

Proyectada especialmente para el tratamiento de líquidos inflamables o para el uso en atmósferas potencialmente explosivas, la serie F se destina para aquellas condiciones en donde no es posible utilizar las normales electrobombas sumergibles.

Intervalo potencia	0,55 kW / 1,5 kW
Intervalo DN caudal	40 mm / 100 mm
Polos/rpm disponibles	2 (2900) ÷ 4 (1450)
Altura máxima	28,9 m
Caudal máximo	16,1 l/seg - 58 m ³ /h

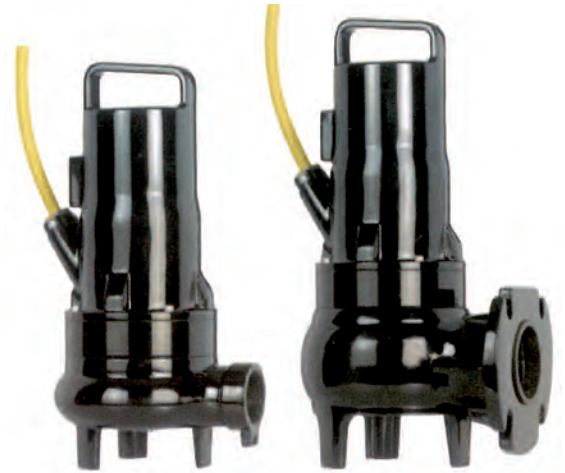

Información general sobre el grupo electromecánico

Tensión y frecuencia de referencia prueba	Monofásicas: 220 ÷ 240 Volt - 50 Hz - Trifásicas: 380 ÷ 415 Volt - 50 Hz
Sentido de rotación	Horario visto desde la parte superior de la electrobomba
Tipo de impregnación	Devanado de doble impregnación resistente a la humedad
Tipo de devanado motor (Monofásico)	Motor de inducción con devanado en seco y termoprotección manual
Tipo de devanado motor (Trifásico)	Motor de inducción con devanado en seco y termoprotección manual

Lista de materiales / Barnizado

Cable del motor	HSSHOUJ	Tornillos	Acero A2
Grupo electromecánico	Hierro fundido EN-GJL-250	Barniz	Expovinílica ecológica
Hidráulica e impulsor	Hierro fundido EN-GJL-250	Camisa de refrigeración	Acero X30Cr13 (AISI420)

Límites de empleo y normativas de referencia

Temperatura máxima del líquido: 40 °C

Profundidad máxima de inmersión: 20 m

- EN 292-1, EN 292-2; CEI EN 60529; UNI ISO 2548; CEI-2-3.
- CEI EN 60204; UNI ISO 6009; UNI EN 1561 - 1563; UNI EN 10098.
- Normas CEI EN 50.014 - CEI EN 50.018 para el funcionamiento en pozos y tanques con gases o líquidos explosivos.
- Procedimientos previstos por el Sistema de Calidad Certificado UNI EN ISO 9001 (ISO 9001), certificado DNV n° SQ 0660-IT.
- Directriz máquinas 89/392/CEE y sucesivas enmiendas (directrices 91/368/CEE, 93/68/CEE), directriz 89/336/CEE compatibilidad electro-magnética.

SERIE F

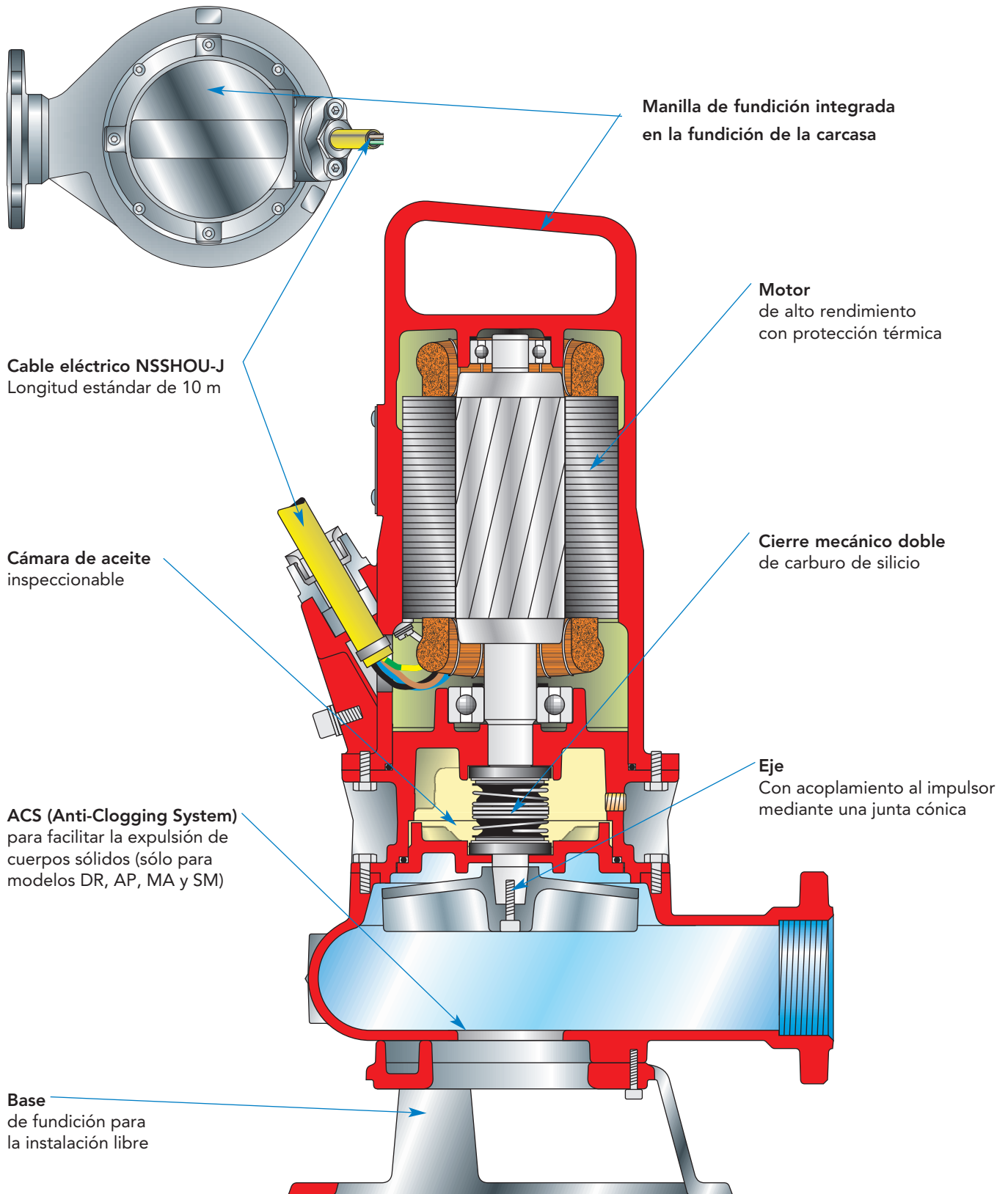

Todos los modelos disponen de CERTIFICACIÓN antiexplosión de acuerdo con la normativa ATEX

CE 0496 Ex II 2 GD EEx d kc IIB T4 T135° C IP68 X

Posibilidad de instalación en lugares con atmósferas y polvos potencialmente explosivos

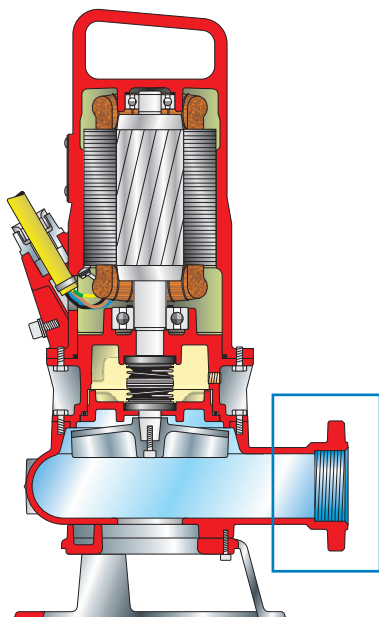

DRENO (DR)

Impulsor multicanal abierto

Pala a ras con la placa de la bomba con sistema ACS (Anti Clogging System) en la aspiración para permitir la expulsión de pequeños cuerpos sólidos.



16+50 mm

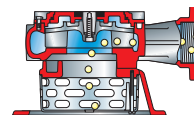

DRAGA (DG)

Impulsor en posición retrasada vortex

Paso libre integral (variable en función de la boca de alimentación)



40+80 mm

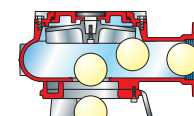

GRINDER (GR)

Impulsor con sistema de trituración

Una cuchilla giratoria garantiza la trituración de los cuerpos sólidos y las fibras.

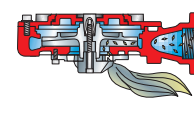

Alta Prevalencia (AP)

Impulsor de altura manométrica elevada

Un proceso específico impide que los cuerpos sólidos y filamentosos puedan enrollarse en el eje. El surco de la placa difusora asegura su expulsión.



10 mm

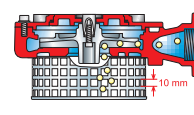

MACS (MA)

Impulsor monocanal abierto

La forma especial de la pala y el surco en la placa difusora aseguran la expulsión de los cuerpos sólidos incluso de grandes dimensiones. Paso libre integral (variable en función de la boca de alimentación).



55 mm

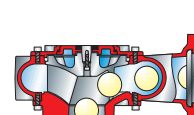

SYSTEM M (SM)

Impulsor monocanal cerrado

La forma especial de la pala garantiza la expulsión de los cuerpos sólidos e impide la formación de obstrucciones. Paso libre integral (variable en función de la boca de alimentación).



48 mm

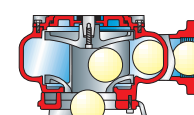

Materiales de fabricación y límites de uso

Carcasa motor	Fundición EN-GJL-250
Eje	Acero X30Cr13 (AISI 420)
Juntas (O-Ring)	Goma VITON
Cierres mecánicos	Carburo de silicio
Cuerpo bomba/impulsor	Fundición EN-GJL-250
Tornillos	Acero INOX A2
Pintura	Expovínica ecológica
Cable	NSSHOU-J

Temperatura de uso máx.	40 °C
PH del líquido	de 6 a 10
Viscosidad del líquido	1 mm ² /s
Servicio	S3 - S1
Prof. de inmersión máx.	20 m
Densidad del líquido	1 kg/dm ³
Pres. acústica máx.	< 70 dB
Arranques / hora máx.	10

DATOS HIDRÁULICOS MODELOS DRF

MODELO	Q=l/s	1	3	5	6	7	8	10	12	14	16
	Q=m ³ /h	3,6	10,8	18	24	25,2	28	36	43,2	50,4	57,6
DRF 75/2/G40V	H = m.c.a.	10	7,5	4,3	2,5						
DRF 75/2/G40H		12	8,5	6,7	4,8	2,4					
DRF 100/2/G40V		9,2	7,8	5,7	4	3,3					
DRF 100/2/G40H		11,6	8,7	7,8	6,4	5	3,2				
DRF 150/2/G50V		12	11	9	8	7,5	7	4,5	2		
DRF 150/2/G50H		16	14	13,5	13	12	11	8	6	2,5	
DRF 200/2/G50V		13	11	9	8	7,5	6,8	4,6	2		
DRF 200/2/G50H		15	14	13	12,5	11,5	10,5	8	6	2,5	
DRF 100/4/65		4,8	4,5	3,8	3,6	3,4	3	2,4	1,7		
DRF 100/4/80		5,3	4,7	4	3,8	3,5	3,1	2,7	2	1,3	
DRF 100/4/100		4,7	4,3	3,9	3,7	3,6	3,3	2,9	2,6	2	1,8

V = SALIDA VERTICAL.

H = SALIDA HORIZONTAL.

CARACTERÍSTICAS TÉCNICAS MODELOS DRF

MODELO	Impulsor	Salida	Paso libre (mm)	Potencia (kW)	Polos	V/~	Corriente (A)	Cable	Peso kg		
DRF 75/2/G40V A1CM/50	De canales múltiples abierto	1½" V	16	0,55	2	230/1	3,9	NSSHOU-J 4G1,5 + 2X0,75	27		
DRF 75/2/G40V A1CT/50		1½" V	16	0,55	2	400/3	1,50		27		
DRF 75/2/G40H A1CM/50		1½" H	16	0,55	2	230/1	3,9		27		
DRF 75/2/G40H A1CT/50		1½" H	16	0,55	2	400/3	1,50		27		
DRF 100/2/G40V A1CM/50		1½" V	16	0,74	2	230/1	4,9		28		
DRF 100/2/G40V A1CT/50		1½" V	16	0,74	2	400/3	1,90		28		
DRF 100/2/G40H A1CM/50		1½" H	16	0,74	2	230/1	4,90		31		
DRF 100/2/G40H A1CT/50		1½" H	16	0,74	2	400/3	1,90		31		
DRF 150/2/G50V A1CM/50		2" V	20	1,10	2	230/1	7,20		31		
DRF 150/2/G50V A1CT/50		2" V	20	1,10	2	400/3	2,90		31		
DRF 150/2/G50H A1CM/50		2" H	20	1,10	2	230/1	7,20		31		
DRF 150/2/G50H A1CT/50		2" H	20	1,10	2	400/3	2,90		31		
DRF 200/2/G50V A1CM/50		2" V	20	1,50	2	230/1	9,80		32		
DRF 200/2/G50V A1CT/50		2" V	20	1,50	2	400/3	3,70		32		
DRF 200/2/G50H A1CM/50		2" H	20	1,50	2	230/1	9,80		32		
DRF 200/2/G50H A1CT/50		2" H	20	1,50	2	400/3	3,70		32		
DRF 100/4/65 A1CT/50			DN65 PN10	50	0,74	4	400/3		2,20		41
DRF 100/4/80 A1CT/5			DN80 PN10	50	0,74	4	400/3		2,20		42
DRF 100/4/100 A1CT/50			DN100 PN10	50	0,74	4	400/3		2,20		47

DATOS HIDRÁULICOS MODELOS DGF

MODELO	Q=l/s	1	2	3	4	6	7	8	9	10	12
	Q=m³/h	3,6	7,3	10,8	14,4	21,6	25,2	28,8	32,4	36	43,2
DGF 75/2/G40V	H = m.c.a.	7,5	7	6	4,5	2					
DGF 75/2/G50H		6,2	5,7	5	4	2,4	1,8	1,5			
DGF 100/2/G40V		8,5	8	7,5	6	3	2				
DGF 100/2/G50V		8,2	7,8	7	6	4	3	2	1		
DGF 150/2/G40V		13,5	12,5	11	9	5	2,5				
DGF 150/2/G40H		15	14	13	12	7,5	5	2,5			
DGF 150/2/G50V		12	11	9,8	8,5	6,3	5	4	3	2	
DGF 150/2/G50H		13,3	12	11	10	7,8	6	5	3,3	3	1,8
DGF 200/2/G40V		16	14	13	12	9	6	3			
DGF 200/2/G40H		17	16	15	13,5	9,5	7,5	4,5	2,5		
DGF 200/2/G50V		13	12,5	11,3	10,2	8	7	6	5	4	1,8
DGF 200/2/G50H		14	13,7	13	12	9,8	8,5	7	5,7	4	1,8
DGF 150/2/G65V		7	6,5	6	5,6	4	3	2,4	1,8		
DGF 200/2/G65V		9	8,5	8	7,5	6	5	4,3	3,5	2,3	1,5

V = SALIDA VERTICAL ROSCA HEMBRA. H = SALIDA HORIZONTAL ROSCA HEMBRA O BRIDA.

MODELO	Q=l/s	2	4	6	8	10	12	14	16
	Q=m³/h	7,2	14,4	21,6	28,8	36	43,2	50,4	57,6
DGF 150/2/65	H = m.c.a.	6	5,2	4,1	3	2,7			
DGF 200/2/65		8,4	7,5	6	4,8	3,4	2		
DGF 150/2/80		4,5	3,8	3,2	2,5	1,8			
DGF 200/2/80		6	5,6	4,5	3,8	3	2,3	1,5	
DGF 100/4/65		7	6,4	5,5	4,5	3,5	2,5	1,8	
DGF 100/4/80		5,8	5,1	4,7	3,7	3,1	2,5	2	1,4

CARACTERÍSTICAS TÉCNICAS MODELOS DGF

MODELO	Impulsor	Salida	Paso libre (mm)	Potencia (kW)	Polos	V/~	Corriente (A)	Cable	Peso kg	
DGF 75/2/G40V A1CM/50	VORTEX	1½" V	40	0,55	2	230/1	3,9	NSSHOU-J 4G1,5 + 2X0,75	27	
DGF 75/2/G40V A1CT/50		1½" V	40	0,55	2	400/3	1,50		27	
DGF 75/2/G50H A1CM/50		2" H	50	0,55	2	230/1	3,9		28	
DGF 75/2/G50H A1CT/50		2" H	50	0,55	2	400/3	1,50		28	
DGF 100/2/G40V A1CM/50		1½" V	40	0,74	2	230/1	4,90		28	
DGF 100/2/G40V A1CT/50		1½" V	40	0,74	2	400/3	1,90		28	
DGF 100/2/G50H A1CM/50		2" H	50	0,74	2	230/1	4,90		29	
DGF 100/2/G50H A1CT/50		2" H	50	0,74	2	400/3	1,90		29	
DGF 150/2/G40V A1CM/50		1½" V	40	1,10	2	230/1	7,20		30	
DGF 150/2/G40V A1CT/50		1½" V	40	1,10	2	400/3	2,90		30	
DGF 150/2/G40H A1CM/50		1½" H	40	1,10	2	230/1	7,20		29	
DGF 150/2/G40H A1CT/50		1½" H	40	1,10	2	400/3	2,90		29	
DGF 150/2/G50V A1CM/50		2" V	50	1,10	2	230/1	7,20		32	
DGF 150/2/G50V A1CT/50		2" V	50	1,10	2	400/3	2,90		32	
DGF 150/2/G50H A1CM/50		2" H	50	1,10	2	230/1	7,20		31	
DGF 150/2/G50H A1CT/50		2" H	50	1,10	2	400/3	2,90		31	
DGF 200/2/G40V A1CM/50		1½" V	40	1,50	2	230/1	9,80		31	
DGF 200/2/G40V A1CT/50		1½" V	40	1,50	2	400/3	3,70		31	
DGF 200/2/G40H A1CM/50		1½" H	40	1,50	2	230/1	9,80		30	
DGF 200/2/G40H A1CT/50		1½" H	40	1,50	2	400/3	3,70		30	
DGF 200/2/G50V A1CM/50		2" V	50	1,50	2	230/1	9,80		33	
DGF 200/2/G50V A1CT/50		2" V	50	1,50	2	400/3	3,70		33	
DGF 200/2/G50H A1CM/50		2" H	50	1,50	2	230/1	9,80		32	
DGF 200/2/G50H A1CT/50		2" H	50	1,50	2	400/3	3,70		32	
DGF 150/2/G65V A1CM/50		2½" V	65	1,1	2	230/1	7,20		31	
DGF 150/2/G65V A1CT/50		2½" V	65	1,1	2	400/3	2,90		31	
DGF 200/2/G65V A1CM/50		2½" V	65	1,5	2	230/1	9,80		33	
DGF 200/2/G65V A1CT/50		2½" V	65	1,5	2	400/3	3,70		33	
DGF 150/2/G65 A1CM/50		2½" H	65	1,1	2	230/1	7,20		32	
DGF 150/2/G65 A1CT/50		2½" H	65	1,1	2	400/3	2,90		32	
DGF 200/2/G65 A1CM/50		2½" V	65	1,5	2	230/1	9,80		34	
DGF 200/2/G65 A1CT/50		2½" H	65	1,5	2	400/3	3,70		34	
DGF 150/2/G80 A1CM/50		3" H	80	1,1	2	230/1	7,20		33	
DGF 150/2/G80 A1CT/50		3" H	80	1,1	2	400/3	2,90		33	
DGF 200/2/G80 A1CM/50		3" H	80	1,5	2	230/1	9,80		35	
DGF 200/2/G80 A1CT/50		3" H	80	1,5	2	400/3	3,70		35	
DGF 100/4/65 A1CT/50			65	65	0,74	4	400/3		2,20	38
DGF 100/4/80 A1CT/50			80	80	0,74	4	400/3		2,20	41

DATOS HIDRÁULICOS MODELOS GRF

MODELO	Q=l/s	1	2	3	4	5	6
	Q=m³/h	3,6	7,2	10,8	14	18	21,6
GRF 150/2/G40H	H = m.c.a.	19	17,5	16	13	8	2
GRF 200/2/G40H		23	21	18	15	11	6

CARACTERÍSTICAS TÉCNICAS MODELOS GRF

MODELO	Impulsor	SALIDA	POTENCIA (KW)	POLOS	V/~	CORRIENTE (A)	CABLE	KG
GRF 150/2/G40H A1CM/50	Multicanal abierto con sistema de trituración	1½" H	1,10	2	230/1	7,20	NSSHOU-J 4G1,5 + 2x0,75	32
GRF 150/2/G40H A1CT/50		1½" H	1,10	2	400/3	2,90		32
GRF 200/2/G40H A1CM/50		1½" H	1,50	2	230/1	9,80		34
GRF 200/2/G40H A1CT/50		1½" H	1,50	2	400/3	3,70		34

DATOS HIDRÁULICOS MODELOS APF

MODELO	Q=L/S	1	2	3	4	5	6	7
	Q=M³/H	3,6	7,2	10,8	14,4	18	21,6	25,2
APF 150/2/G40H	H = m.c.a.	19	18	17	15	13	8	4
APF 200/2/G40H		22	21	18	17	14	11	7

CARACTERÍSTICAS TÉCNICAS MODELOS APF

MODELO	Impulsor	Salida	Potencia (kW)	Polos	V/~	Corriente (A)	Cable	kg
APF 150/2/G40H A1CM/50	Multicanal abierto de altura de impulsión elevada	1½" H	1,10	2	230/1	7,20	NSSHOU-J 4G1,5 + 2x0,75	32
APF 150/2/G40H A1CT/50		1½" H	1,10	2	400/3	2,90		32
APF 200/2/G40H A1CM/50		1½" H	1,50	2	230/1	9,80		34
APF 200/2/G40H A1CT/50		1½" H	1,50	2	400/3	3,70		34

DATOS HIDRÁULICOS MODELOS MAF

MODELO	Q=l/s	2	4	6	8	10	12	14	15
	Q=m³/h	7,2	14,4	21,6	28,8	36	43,2	50,4	54
MAF 100/4/65	H = m.c.a.	5,5	4,5	3,8	3,1	2,5	1,8		
MAF 100/4/80		5,8	4,8	4	3,3	2,5	1,8	1	
MAF 100/4/100		5,5	4,8	4	3,5	3,1	2,7	2,2	1,5

CARACTERÍSTICAS TÉCNICAS MODELOS MAF

MODELO	Impulsor	Salida	Paso libre (mm)	Potencia (kW)	Polos	V/~	Corriente (A)	Cable	kg
MAF 100/4/65 A1CT/50	Monocanal abierto	65	55	0,74	4	400/3	2,20	NSSHOU-J 4G1,5 + 2x0,75	48
MAF 100/4/80 A1CT/50		80	55	0,74	4	400/3	2,20		48
MAF 100/4/100 A1CT/50		100	55	0,74	4	400/3	2,20		48

DATOS HIDRÁULICOS MODELOS SMF

MODELO	Q=l/s	2	4	6	8	10	12	14
	Q=m³/h	7,2	14,4	21,6	28,8	36	43,2	50,4
SMF 100/2/G50H	H = m.c.a.	7,5	6	4,5	2,5			
SMF 150/2/G50H		12	10,5	8	7	5,5	3	
SMF 200/2/G50H		14	13	11,5	9,5	7,5	5,5	4

CARACTERÍSTICAS TÉCNICAS MODELOS SMF

MODELO	Impulsor	Salida	Paso libre (mm)	Potencia (kW)	Polos	V/~	Corriente (A)	Cable	kg
SMF 100/2/G50H A1CM/50	Monocanal cerrado	2" H	48	0,74	2	230/1	4,90	NSSHOU-J 4G1,5 + 2x0,75	34
SMF 100/2/G50H A1CT/50		2" H	48	0,74	2	400/3	1,90		34
SMF 150/2/G50H A1CM/50		2" H	48	1,10	2	230/1	7,20		35
SMF 150/2/G50H A1CT/50		2" H	48	1,10	2	400/3	2,90		35
SMF 200/2/G50H A1CM/50		2" H	48	1,50	2	230/1	9,80		36
SMF 200/2/G50H A1CT/50		2" H	48	1,50	2	400/3	3,70		36